

Eclipse ThermJet Burners

for preheated combustion air

Model TJPCA1000
Version 2

PARAMETER		SPECIFICATION		
		Nat. Gas	Propane	Butane
Maximum Input Btu/hr (kW)		10,000,000 (2930)	10,000,000 (2930)	10,000,000 (2930)
Minimum Input, On-ratio Btu/hr (kW)		1,000,000 (293)	1,000,000 (293)	1,000,000 (293)
Gas Inlet Pressure "w.c. (mbar) • Fuel pressure at gas inlet (Tap "B"— see page 3)	ambient	5.5 (13.7)	5.5 (13.7)	5.5 (13.7)
	300° F	7.1 (17.7)	7.1 (17.7)	7.1 (17.7)
	700° F	10.1 (25.1)	10.1 (25.1)	10.1 (25.1)
	1000° F	-----	-----	-----
Air Inlet Pressure "w.c. (mbar) • 15% excess air at maximum input (Tap "A" – see page 3)	ambient	4.0 (10.0)	4.0 (10.0)	4.0 (10.0)
	300° F	5.6 (13.9)	5.6 (13.9)	5.6 (13.9)
	700° F	8.6 (21.4)	8.6 (21.4)	8.6 (21.4)
	1000° F	-----	-----	-----
High Fire Flame Length Inches (mm)		<149 (3785)	<149 (3785)	<154 (3912)
Flame Detection		U.V. scanner available for all combustors		
Fuel		Natural Gas, Propane, Butane <i>For any other mixed gas, contact Eclipse for orifice sizing.</i>		

- All information is based on laboratory testing in neutral (0.0" w.c.) pressure chamber. Different chamber size and conditions may affect the data.
- All information is based on standard combustor design. Changes in the combustor will alter performance and pressures.
- All inputs based upon gross calorific values.
- Eclipse reserves the right to change the construction and/or configuration of our products at any time without being obliged to adjust earlier supplies accordingly.
- Plumbing of air and gas will affect accuracy of orifice readings. All information is based on generally acceptable air and gas piping practices.

Performance Graphs

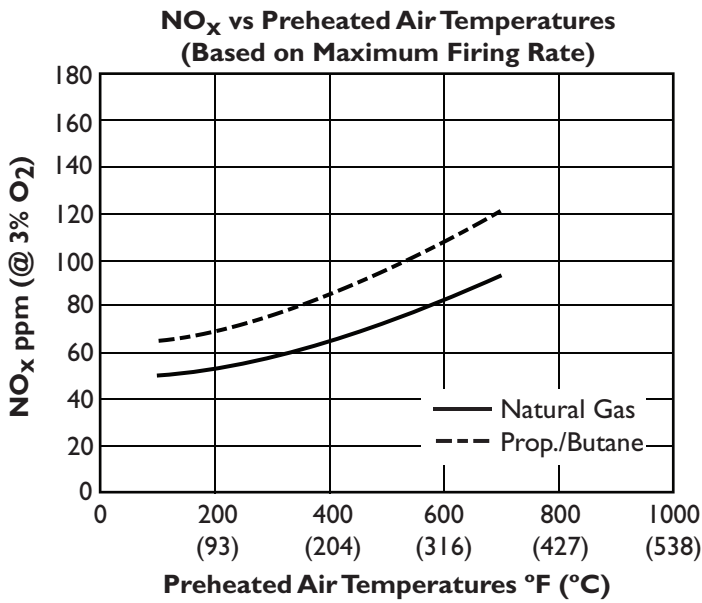
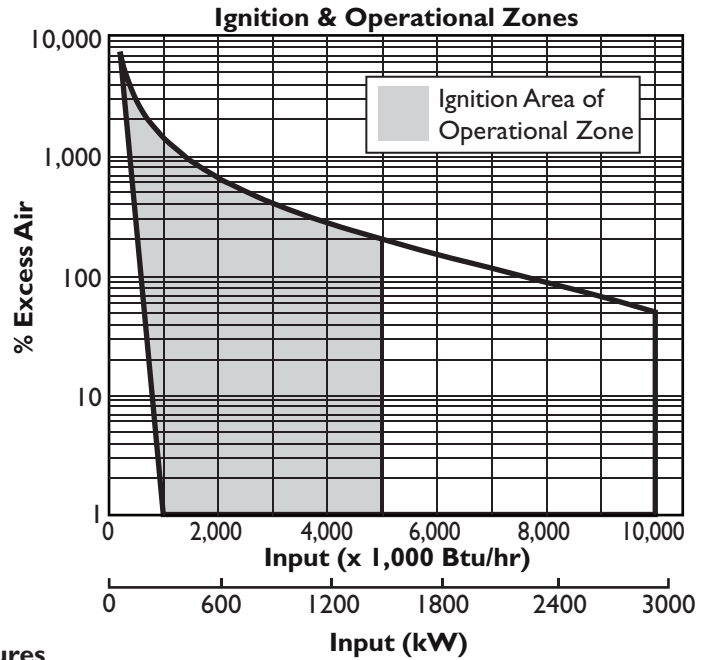

Emissions from the burner are influenced by:

- Fuel type
- Combustion air temperature
- Firing rate
- Chamber Conditions
- Percent of excess air

For estimates of other emissions, contact Eclipse.

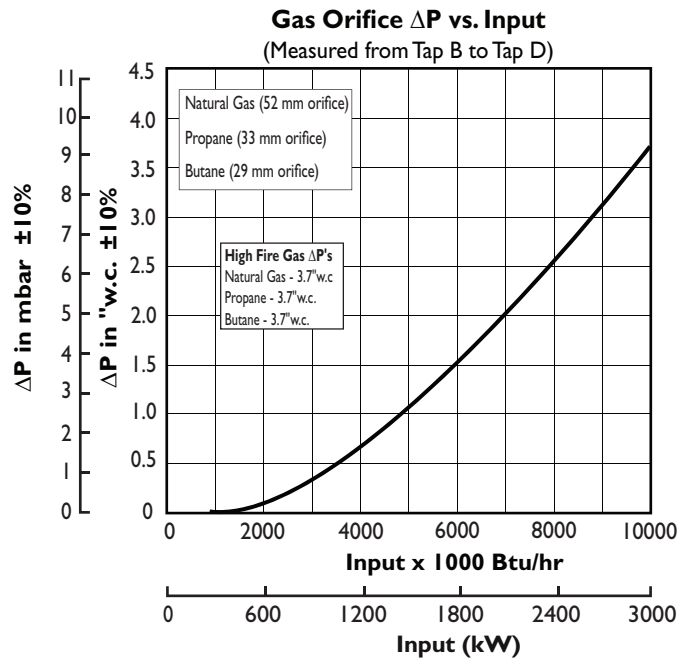

Dimensions & Specifications Millimeters (Inches)

Burner Housing

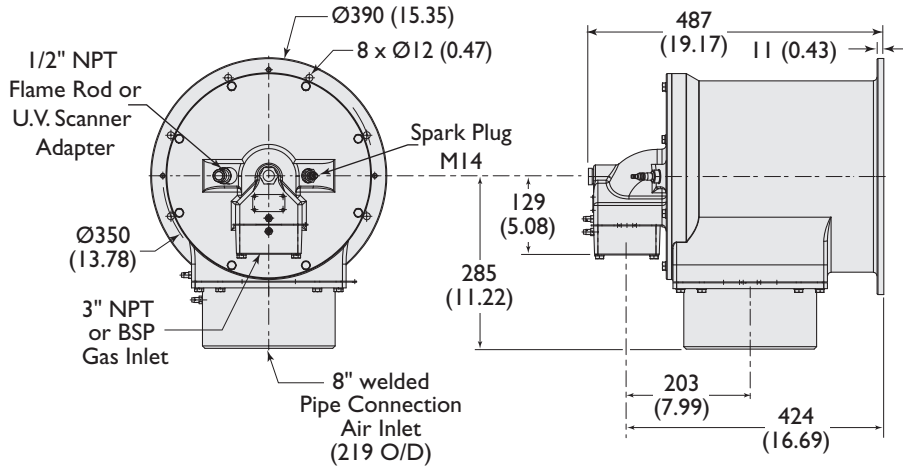

Burner weight less combustor: 133 lb (60 kg)

Tap Locations

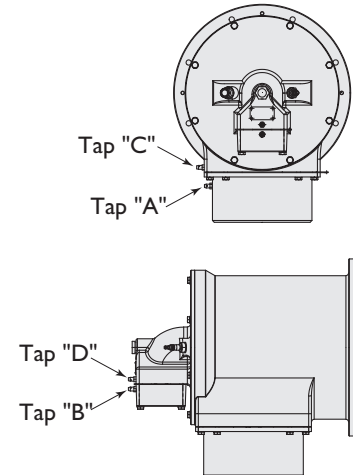

Combustor

Exhaust outlet diameter : High Velocity : $\text{Ø}220$ (8.66)
Medium Velocity : $\text{Ø}250$ (9.84)

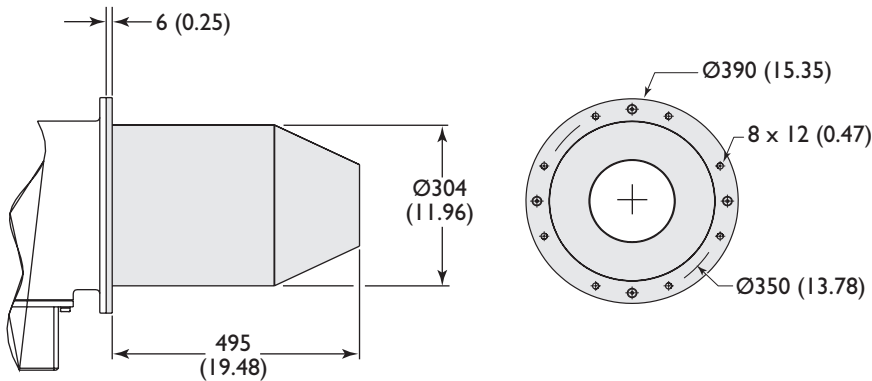

Alloy Tube (AISI 310)

Weight : 21 lb (9.5 kg)
Max. Chamber Temp : 1,750°F (950°C)

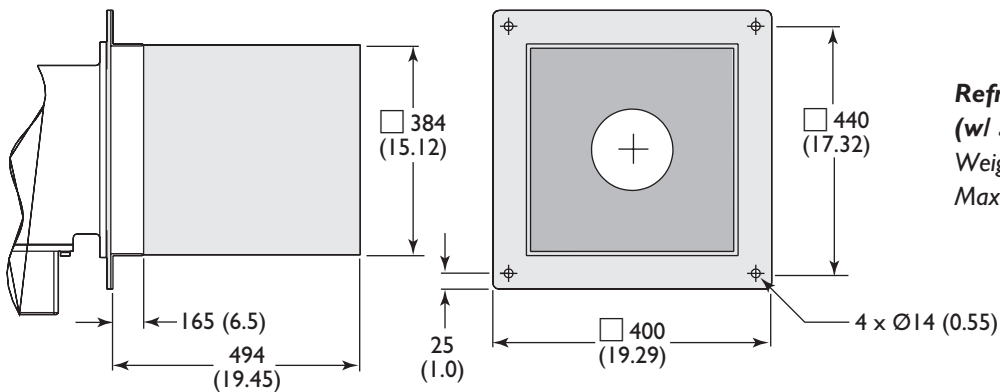

Refractory Block

(w/ 330 SS wrapper)
Weight : 310 lb (141 kg)
Max. Chamber Temp : 2,800°F (1535°C)

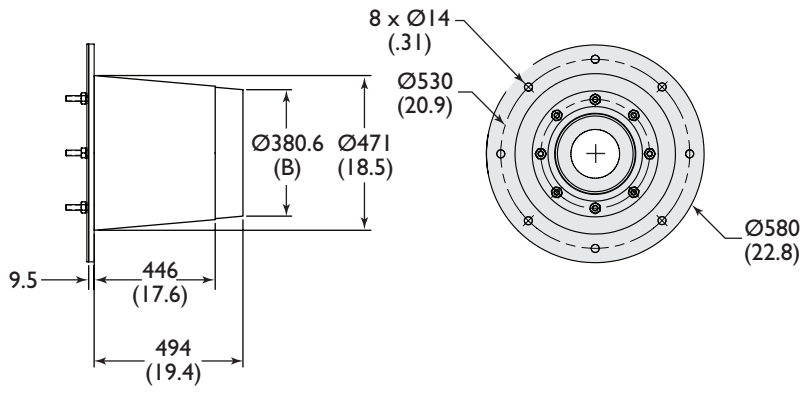

Down Firing Block

Weight: 290 lb (131.54 kg)

Max. Chamber Temp: 2800°F (1535°C)



Offered By:

Power Equipment Company
2011 Williamsburg Road
Richmond, Virginia 23231
Phone (804) 236-3800
Fax (804) 236-3882

www.peconet.com